



Poltrona

# EREDITA

*Por Mauricio Bomfim*

Poltrona

# EREDITA

**ASSENTO:** FIXO + D28 + FIBRA

**ENCOSTO:** FIXO + D28 + FIBRA

**ESTRUTURA:** TINGIMENTOS - LÍNEN, NOGUEIRA, EBANIZADO,  
NATURAL, IMBUIA E NOZES

**MADEIRA:** TAUARI

**OBSERVAÇÕES:** OS TINGIMENTOS LÍNEN E NATURAL RESSALTAM  
AS CARACTERÍSTICAS NATURAIS DA MADEIRA, PODENDO  
APRESENTAR DIFERENÇA DE TONALIDADE

**SEAT:** FIXED + D28+ FIBER

**BACKREST:** FIXED + D28 + FIBER

**STRUCTURE:** DYEINGS - LINEN, WALNUT, EBANIZED,  
NATURAL, IMBUIA AND WALNUTS

**WOOD:** TAUARI

**OBSERVATIONS:** LINEN AND NATURAL DYES  
HIGHLIGHT THE NATURAL CHARACTERISTICS OF  
WOOD, AND MAY SHOW DIFFERENCES IN TONES

**ASIENTO:** FIJO + D28 + FIBRA

**RESPALDO:** FIJO + D28 + FIBRA

**ESTRUTURA:** TINTURAS - LINO, NOGAL, EBANIZADOS,  
NATURALES, IMBUIA Y NUECES

**MADERA:** TAUARI

**OBSERVACIONES:** EL LINO Y LOS TINTES NATURALES  
RESALTAN LAS CARACTERÍSTICAS NATURALES DE LA  
MADERA Y PUEDEN MOSTRAR DIFERENCIAS DE TONOS

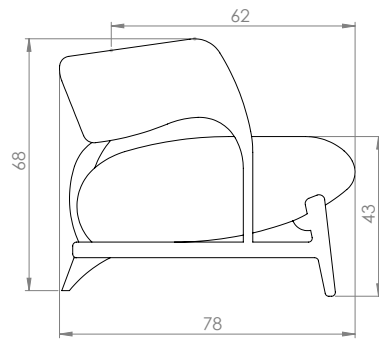
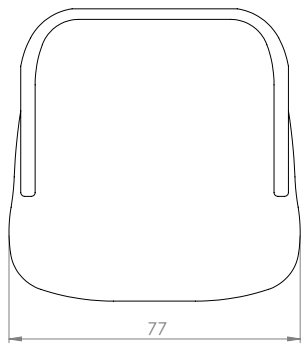

**Configuração de Poltrona**

Poltrona 77 - 1 ass(77 x 78)

